

# INSTALLATION INSTRUCTIONS



# OPTI-FLOAT®

The next generation of float.

**COX**®  
RESEARCH

**PROCESS > POWER > LIGHT**

## THE OPTI-FLOAT® LEVEL DETECTOR

Combining new technology with a familiar device, the Opti-Float® level detector is a revolutionary innovation in discrete level detectors. The new float is made of safe, recyclable materials, is mercury and lead free, and is engineered for many years of service.

The design of the Opti-Float® level detector is amazingly simple. Using fiber optic cable, a beam of light is transmitted from an LED in a remote transceiver down to the float, where the beam makes and breaks depending on the tilt of the float. When the transceiver detects the presence or absence of light, a relay is activated in the transceiver, which can then operate other devices. The transceivers are all dual, din rail mounted units, that can connect to two floats. Additional transceivers can be used for additional floats.

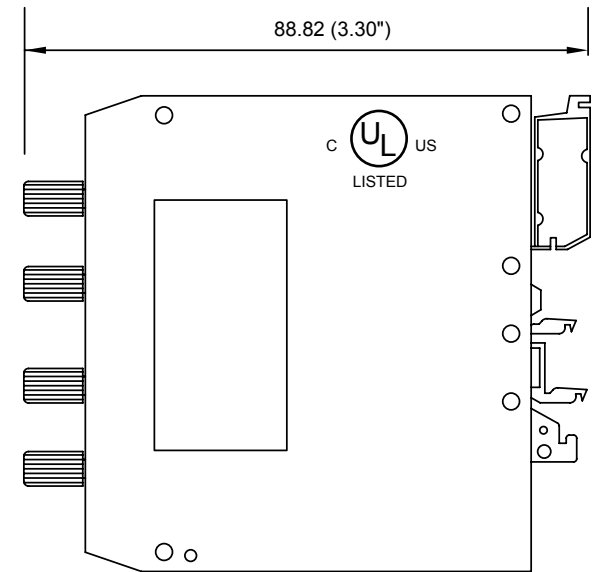
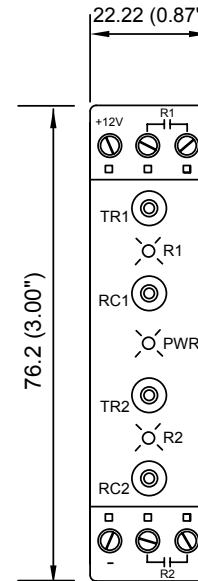

Transceiver

## TECHNICAL DATA

### DUAL TRANSCEIVER:

Operating voltage: 12 VDC +/- 10%

Power consumption: 1.2 VA max.

Output: Relay SPDT, 3 amp at 240 VAC  
each channel

Operating temperature: -25 to +55C

### FLOAT:

Housing material: Polypropylene

Cable: PVC over dual plastic fibers

Operating wavelength: 400 to 1200 nm

Operating temperature: -25 to +70C

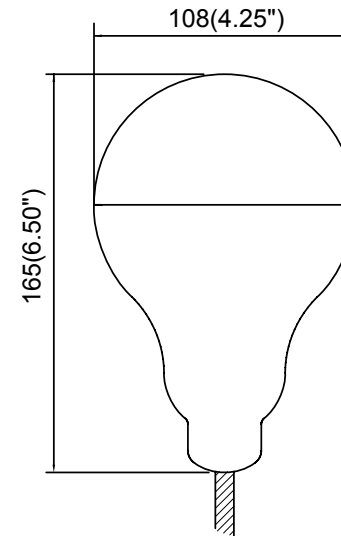

Float

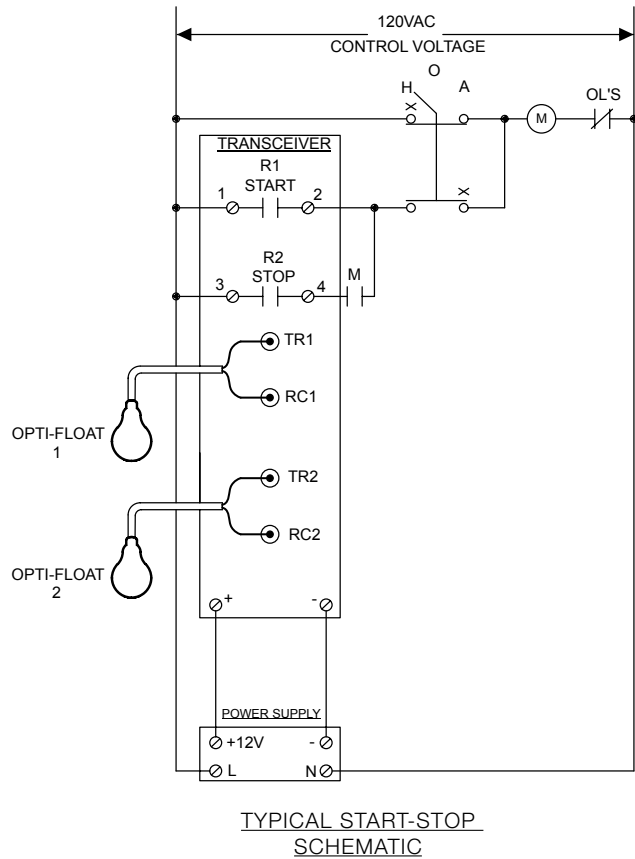

## The OPTI-FLOAT® Transceiver

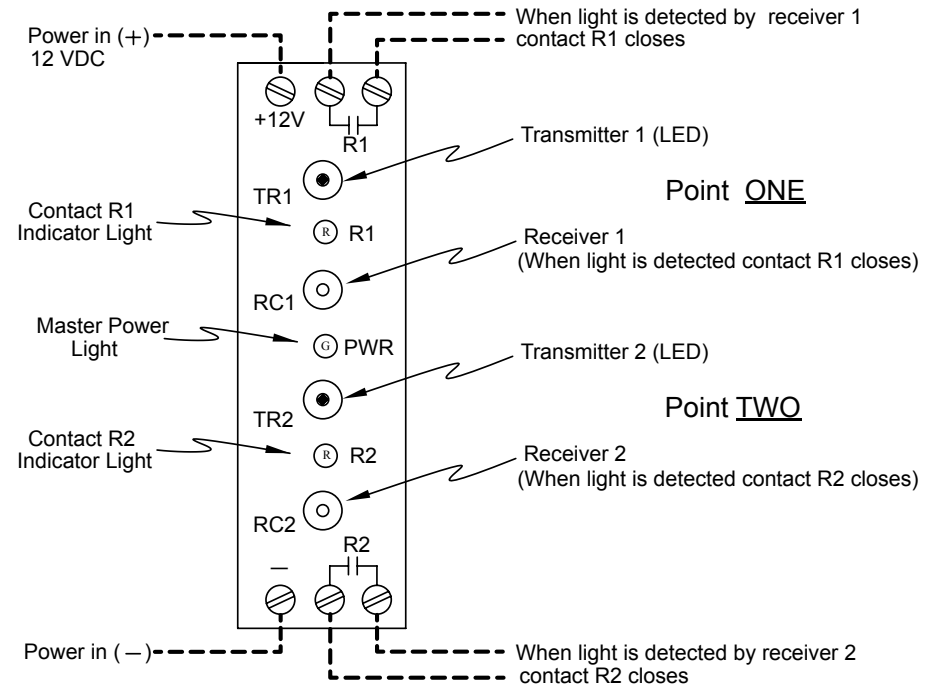

WRONG

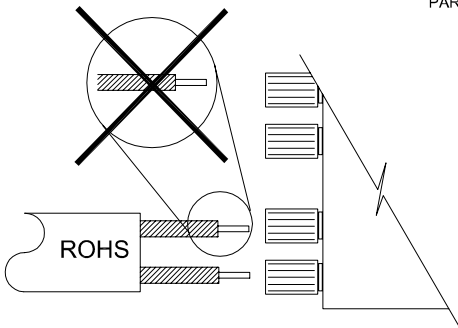

CORRECT

CUT WITH RAZOR CUTTER  
PART # CC1 OR CC2

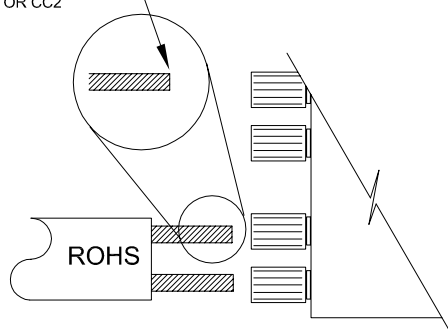

FIBER CONNECTION  
INSTRUCTIONS

# INSTALLATION INSTRUCTIONS

1. Proper installation of Opti-Float® level detectors will insure long trouble free operation.
2. The transceivers are dual units capable of operating 2 floats. Transceivers have relay outputs that are factory shipped in the most common mode, which is normally open – float tilted down, beam blocked, relay de-energized, relay contact open. Relay contacts close when the float is tilted up.
3. To change to a normally closed mode, open the transceiver housing by pulling off the left side panel. No tools are needed. Locate the 2 jumpers JP1 and JP2. Pull the removable shunts off and move one position forward to the NC position. The relay contact will now be normally closed and will open when the float is tilted up.
4. Install transceivers on a din rail mounting. Connect a 12 VDC, 10 watt power supply to the + and – terminals. Connect the relay contacts, R1 and R2, to the control circuit.
5. The relays can be connected directly in the motor starter contactor coil circuit (240 VAC max.). For maximum relay life, it is recommended that interface relays be used on starters larger than NEMA size 2.
6. Strip off the outer sheath of the pair of fiber optic cables as far as necessary. Use care so as not to cut the fiber cables.
7. The fiber cables consist of a plastic light fiber with a thin polyethylene covering. Do not strip off this covering. Square cut the ends of the fiber cable using a sharp razor blade, box cutter, cigar cutter or a simple device available from Cox Research. Look at the cut end and verify that it is a clean cut with no polyethylene covering the light fiber. Re-cut if necessary. Polishing of the end is not required.
8. Completely loosen the cinch nuts on the transceiver but do not remove them. Insert the fiber cables into the ends until they bottom out. The fiber cables will insert approximately 16mm (5/8”) from the end of the fully loosened thumb screw.
9. Hand tighten the cinch nuts. Do not use any tool for this operation. Verify that the fiber cables are securely in place. Also make sure that the cables enter the connectors straight. Undue lateral tension will keep the fiber from mating with the transmitter and receiver devices inside the housing. The minimum recommended bending radius of the fiber cables is 25mm (1”).
10. The blue connector is the light source and the black connector is the light receiver. It does not matter which fiber cable is inserted into which connector, just make sure that they are matching pairs of the same float.
11. When in operation, a float that is tilted above horizontal will illuminate its respective red led, R1 or R2, on the front of the transceiver. It does not matter whether the relay is connected normally open or normally closed. The green PWR light will illuminate when the transceiver has power.
12. Spare transmitter and receiver connectors should be covered with the plastic dust covers shipped with each unit. This will not only prevent contaminants from getting into the device, it will also prevent ambient light from entering the spare receiver which may cause it to switch on and off.
13. It is recommended that float cables be ordered with the correct length of cable. However, in the event that a splice is necessary, the cable can be spliced with one pair of splices only. Splices are tubular with cinch nuts on each end. Contact Cox Research for splice kits.
14. Maximum recommended cable lengths are 30m (100') without splices and 20m (66') with one set of splices. Contact Cox Research if you have more demanding requirements.

15. When installing the cable make sure that the cables are not unduly kinked, stressed, rubbing against sharp objects or installed such that the bending radius of the cable is less than 25mm (1”) in any location. Larger loops are recommended.
16. For optimum operation when attached to support, tether the float with about 100mm (4”) of cable slack.
17. Attach the floats to support cable, chain, rod or other devices using standard wire ties. Attach the float cable perpendicular to the support and make an additional parallel attachment about 100mm (4”) above the first one. Place a 5/16” ID x 3/8” OD split vinyl protective sleeve around the float cable where the attachments are to be made. Orient the split so that the wire ties do not contact the float cable. See instructions supplied with Cox Research cable attachment devices for proper installation.
18. Where float wires enter a junction or terminal box adjacent to a control panel, it is recommended that the float cable not be cut and spliced, but brought directly through the box to the control panel. Make a loop in the cable such that a splice could be installed at a later date if necessary. If desired, the sheath of the optical cable can be removed where individual fibers are needed to be installed through seal off fittings.
19. Although designed to take a large amount of abuse, for maximum life, it is recommended that the Opti-Float® level detectors not be abused by striking them against the walls of wet wells.
20. A complete fully assembled, UL listed, externally mounted Retro-Kit consisting of floats, transceivers, power supply and enclosure is available from Cox Research. Contact us with your requirements.

Patented. Others Pending.

Opti-Float® and Optical Float® are registered trademarks of Cox Research and Technology, Inc.

---

## LIMITED WARRANTY

Cox Research and Technology, Inc. ("Cox") warrants to the original purchaser (the "Customer") that the Optical Float® systems and products will be free of defects in materials or workmanship, for a period of 3 years from the date of purchase. This warranty is void on products that have been, in our judgment, tampered with, abused, improperly stored, improperly wired, improperly installed, misused or subjected to high voltages either through negligence, power surges, lightning or other sources; modified, altered or adapted without Cox's written consent; or used with equipment not covered by this warranty, to the extent that problems are attributable to such use.

The Customer is required to obtain a return authorization number from Cox before returning any products. The customer is responsible for all expenses including removal, re-installation and shipping necessary to deliver the returned products to the factory for evaluation, repair, or replacement. Cox's sole liability under this Limited Warranty is, at its option, to repair or replace any products that are found defective in materials or workmanship, or to refund the purchase price paid for the defective product.

**Disclaimer of Further Warranties.** THE LIMITED WARRANTY SET FORTH ABOVE IS THE EXCLUSIVE WARRANTY APPLICABLE TO THIS CONTRACT, AND COX EXPRESSLY DISCLAIMS ALL OTHER WARRANTIES OR REMEDIES, INCLUDING WARRANTIES OF MERCHANTABILITY AND FITNESS FOR A PARTICULAR PURPOSE, WHETHER THE SAME ARE WRITTEN, VERBAL, IMPLIED, OR STATUTORY. THE CUSTOMER IS SOLELY RESPONSIBLE FOR DETERMINING THE SUITABILITY OF COX OPTICAL FLOAT SYSTEM PRODUCTS FOR THE CUSTOMER'S INTENDED PURPOSES, AND COX SHALL NOT BE LIABLE FOR THE SUITABILITY OF ITS OPTICAL FLOAT SYSTEM PRODUCTS FOR ANY PARTICULAR PURPOSE.

**Limitation of Liability.** Customer's rights and remedy are governed exclusively by the terms and conditions of this Limited Warranty and Customer expressly waives any claim based upon contract, tort, strict liability, or otherwise. Under no circumstances shall Cox be liable for any incidental, consequential, or special damages, losses, or expenses incurred by Customer or any third party arising from this offer of sale or the performance of Optical Floats systems hereunder. Under no circumstances shall the amount of any claim for damages or liability exceed the amount paid by Customer for products provided by Cox hereunder. This Limited Warranty may only be modified in writing by an officer of Cox, and is the entire agreement between the parties hereto. If any provision of this Limited Warranty is determined to be void, the remaining provisions are deemed valid and enforceable.

---

Cox Research and Technology, Inc.

225.756.3271 > 800.910.9109 > f: 225.755.1030  
14697 South Harrell's Ferry Road  
Baton Rouge, LA. 70816  
optifloat.com

041309